



US007677755B2

(12) **United States Patent**
Kim

(10) **Patent No.:** **US 7,677,755 B2**
(45) **Date of Patent:** **Mar. 16, 2010**

(54) **VARIABLE ORIENTATION APPLIANCE MOUNT**

(75) Inventor: **Paul Y. Kim**, Santa Ana, CA (US)

(73) Assignee: **Surefire, LLC**, Fountain Valley, CA (US)

(*) Notice: Subject to any disclaimer, the term of this patent is extended or adjusted under 35 U.S.C. 154(b) by 474 days.

5,826,363 A	10/1998	Olson	
6,508,027 B1	1/2003	Kim	
6,622,416 B2	9/2003	Kim	
6,675,521 B1	1/2004	Kim	
6,732,987 B2 *	5/2004	Wooten et al.	248/229.1
6,895,708 B2	5/2005	Kim et al.	
6,951,409 B2 *	10/2005	Hsien	362/191
6,994,449 B2	2/2006	Kim	
7,117,624 B2	10/2006	Kim	
7,226,183 B2 *	6/2007	Galli et al.	362/191
7,325,352 B2 *	2/2008	Matthews et al.	42/85

(21) Appl. No.: **11/804,067**

(22) Filed: **May 16, 2007**

(65) **Prior Publication Data**

US 2008/0283709 A1 Nov. 20, 2008

(51) **Int. Cl.**
F21L 4/00 (2006.01)

(52) **U.S. Cl.** **362/190**; 362/191

(58) **Field of Classification Search** 248/346.03, 248/346.06, 346.07; 362/110, 113, 114, 362/119, 120, 190, 191, 202, 208, 396; 42/111, 42/124, 125; 224/271, 448

See application file for complete search history.

(56) **References Cited**

U.S. PATENT DOCUMENTS

2,601,613 A *	6/1952	Jahncke	248/229.15
2,632,251 A	3/1953	Weaver	
3,750,318 A *	8/1973	Burris	42/127
4,328,624 A	5/1982	Ross	
5,086,566 A *	2/1992	Klump	42/126
5,590,484 A	1/1997	Mooney et al.	
5,787,630 A *	8/1998	Martel	42/125

OTHER PUBLICATIONS

United States Department of Defense, Military Standard: Dimensioning of Accessory Mounting Rail for Small Arms Weapons, MIL-STD-1913, Feb. 3, 1995.

Surefire, LLC, "Surefire Tactical Products 2005" catalog, pp. 27 and 28, Feb. 2005.

* cited by examiner

Primary Examiner—Hargobind S Sawhney
(74) *Attorney, Agent, or Firm*—David Weiss

(57) **ABSTRACT**

A mount for securing an appliance such as a light beam generator to a support or other object at various selected orientations of the appliance. A preferred embodiment of the mount includes a circular element having a wedge-shaped circumferential portion and a plurality of rotationally spaced diametric grooves, and a securement device including first and second opposed surfaces for securely engaging the circular element's wedge-shaped circumferential portion, the securement device including a bar extending between the first and second opposed surfaces for engaging a selected one of the diametric grooves.

19 Claims, 2 Drawing Sheets

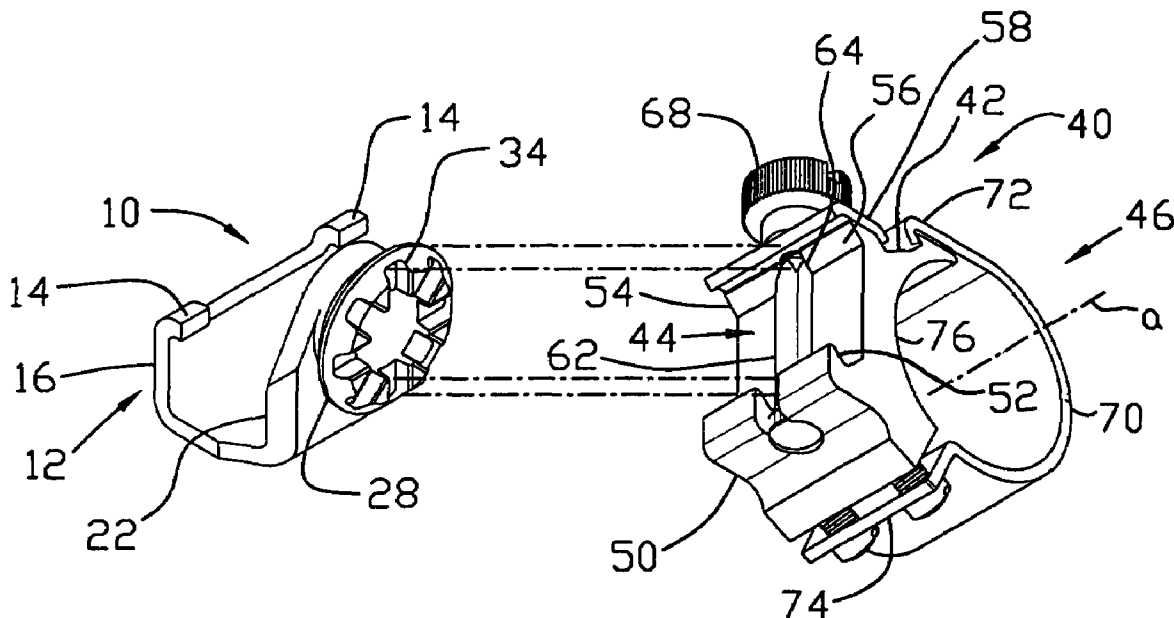

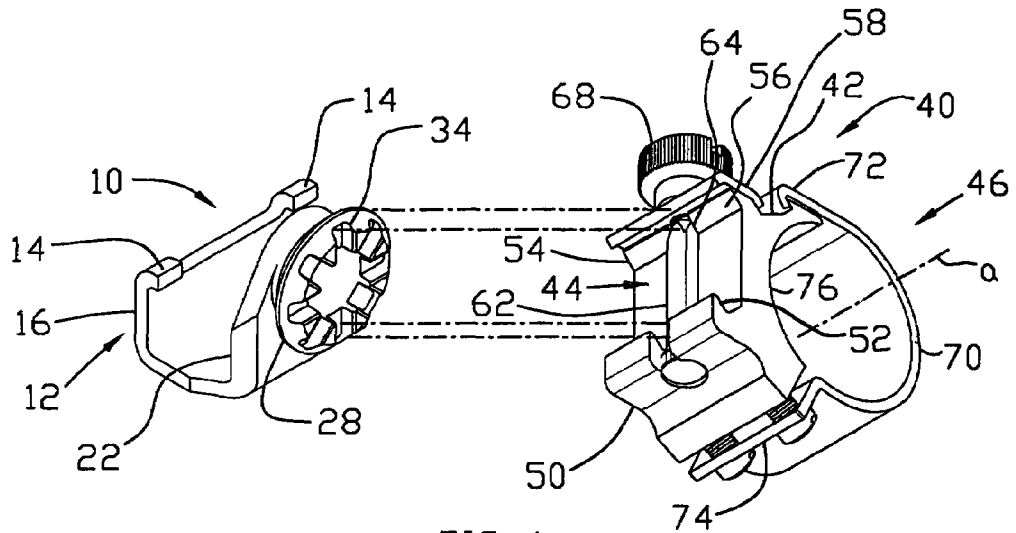

FIG. 1

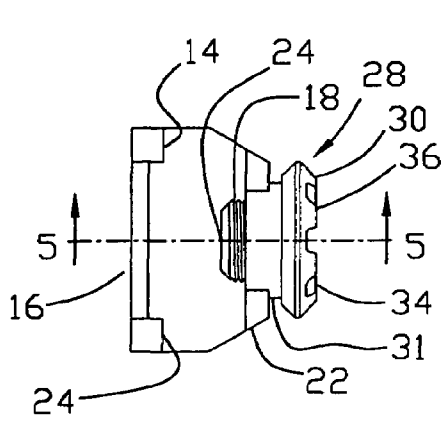

FIG. 2

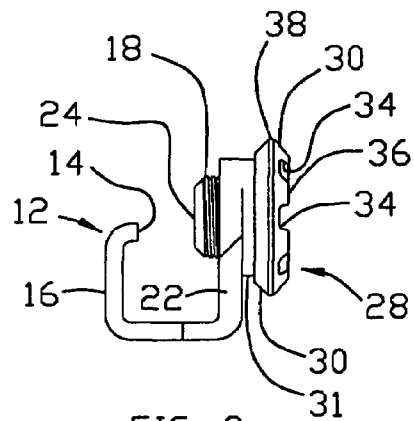

FIG. 3

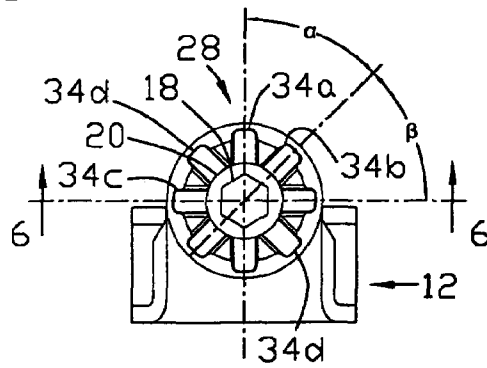

FIG. 4

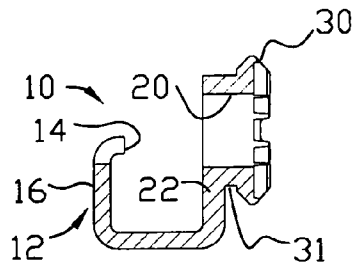

FIG. 5

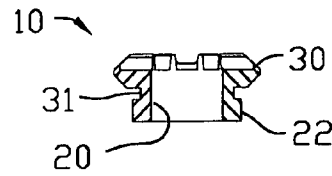

FIG. 6

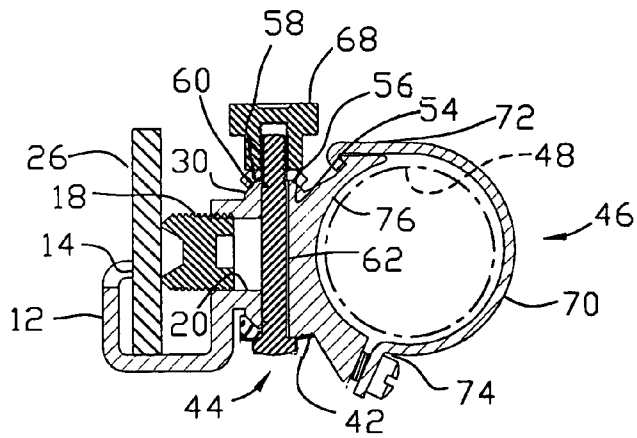

FIG. 7

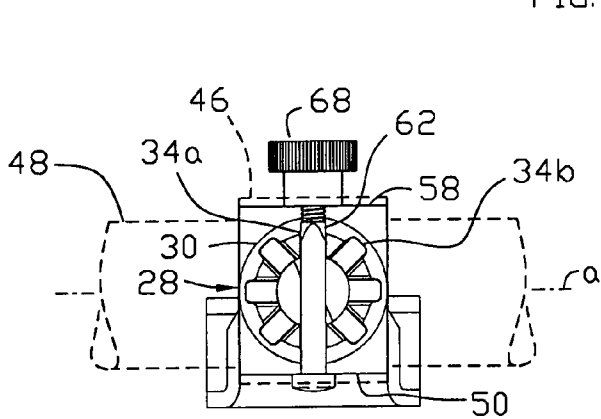

FIG. 8

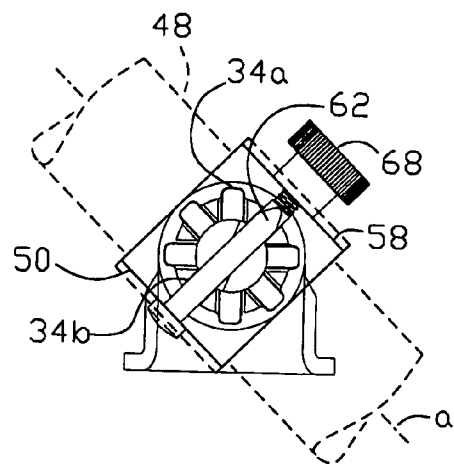

FIG. 9

1

VARIABLE ORIENTATION APPLIANCE MOUNT

BACKGROUND OF THE INVENTION

This invention relates to mounts for securing a device to an object, and more particularly to a mount for securing an appliance such as a flashlight to a support or other object at various selected orientations of the appliance.

Appliances such as light beam generators, including flashlights and laser beam devices, have long been adapted for being secured to longitudinal rails on firearms. Such appliances are either equipped with a securement device for mounting engagement with the rail, or the appliance may be secured to an intermediate or interface securement device which in turn may be mounted to the rail. Such longitudinal rails are well known in the firearms art, including a longitudinal rail commonly known as a Picatinny rail and a longitudinal rail commonly known as a Universal rail, comprising a series of longitudinally spaced-apart ribs having wedge-shaped ends and separated by transverse slots. Examples of such longitudinal rails are disclosed in U.S. Pat. Nos. 6,508,027 and 6,622,416, both issued to Paul Y. Kim and incorporated herein by reference.

A device for securement to such longitudinal rails typically includes a pair of longitudinal members having opposed V-shaped surfaces for matingly engaging the wedge-shaped surfaces of the longitudinal rail, and a bar transversely extending between the pair of V-shaped surfaces. The operator places the securement device to the longitudinal rail with the device's V-shaped surfaces engaging the rail's wedge-shaped surfaces and with the device's transverse bar inserted in a selected one of the rail's transverse slots for locking the securement device in a desired longitudinal location on the longitudinal rail.

SUMMARY OF THE INVENTION

The present invention preferably utilizes securement devices typically used with longitudinal rails such as Picatinny or Universal rails. However, the present invention does not utilize a longitudinal rail but instead provides a grooved circular mount which may be secured to a support or other object, and to which the V-shaped surfaces and transverse bar of the securement device may be applied for securely mounting such securement device—or an appliance secured to or integral with the securement device—to the circular mount and hence to the support or other object. In its preferred embodiment, the circular mount includes a plurality of rotationally spaced diametric grooves for being selectively engaged by the transverse bar of the securement device, for permitting the securement device and hence the appliance to be mounted to the object at various selected orientations.

According to one aspect of the present invention, there is provided apparatus for mounting a device to an object, comprising: a mount adapted for being removably secured to the object, the mount including a circular element having a wedge-shaped circumferential portion and at least one diametric groove; and a device including first and second opposed surfaces for securely engaging the circular element at the wedge-shaped circumferential portion, the device including a bar extending between the first and second opposed surfaces for engaging the at least one diametric groove. The at least one diametric groove is configured for engageably receiving at least a portion of the bar. The device

2

is preferably adapted for clamping its opposed surfaces to the circular element at such circular element's wedge-shaped circumferential portion.

In the preferred embodiment, the circular element includes a plurality of rotationally spaced diametric grooves, each of which is configured for engageably receiving at least a portion of the bar. The device is preferably adapted for clamping its opposed surfaces to the circular element at the circular element's wedge-shaped circumferential portion when the bar engages a selected one of the diametric grooves.

The device may be adapted for securing an appliance such as a light beam generator thereto, or the device may itself include an appliance such as a light beam generator.

BRIEF DESCRIPTION OF THE DRAWINGS

The novel features believed to be characteristic of the present invention, together with further advantages thereof, will be better understood from the following description considered in connection with the accompanying drawings in which a preferred embodiment of the invention is illustrated by way of example. It is to be expressly understood, however, that the drawings are for the purpose of illustration and description only and are not intended as a definition of the limits of the invention.

FIG. 1 is a perspective view of a mount for securing a device to an object in accordance with the present invention, shown with an example of a device adapted for being secured to the mount, the mount and device being shown in exploded configuration;

FIG. 2 is a top view of the preferred embodiment of the mount shown in FIG. 1;

FIG. 3 is a side view of the mount of FIG. 1;

FIG. 4 is a front view of the mount of FIG. 1;

FIG. 5 is a cross-sectional view of the mount of FIG. 1, taken along the line 5-5 of FIG. 2 and viewed in the direction of the appended arrows, the mount being shown without its bracket set screw for clarity;

FIG. 6 is a cross-sectional view of the mount of FIG. 1, taken along the line 6-6 of FIG. 4 and viewed in the direction of the appended arrows, the mount of FIG. 6 being shown without its bracket set screw for clarity;

FIG. 7 is a cross-sectional view of the mount as in FIG. 5 but including its bracket set screw, shown secured to an object and to the device shown in FIG. 1, the device shown secured to a further device such as a flashlight or other light beam generator;

FIG. 8 is a front view of the mount as in FIG. 4, shown with securement components of the device including the light beam generator (partially broken away and/or in phantom) as in FIG. 7, with the securement components and the light beam generator disposed in one orientation on the mount; and

FIG. 9 is similar to FIG. 8, but with the securement components and the light beam generator disposed in a second orientation on the mount.

DETAILED DESCRIPTION OF THE PREFERRED EMBODIMENT

Turning to FIGS. 1-7, a mount 10 comprising a preferred embodiment of the present invention includes a generally U-shaped bracket 12 with two inwardly disposed mounting prongs 14 spaced along a leg 16 of the U. A mounting screw, such as set screw 18, is threadedly disposed in a threaded bore 20 through the opposing leg 22 of the U, the bearing end 24 of the set screw 18 facing the prongs 14 and spaced therefrom so that the bracket 12 may be placed to an object 26 (see FIG. 7)

with the prongs **14** and the set screw **18** on opposite sides of the object **26**. Further inwardly threading or tightening of the set screw **18** will cause the bracket **12** to be captured to the object **26** and clampingly secured thereto, and subsequent unthreading or loosening of the set screw **18** will release the securement of the bracket **12** from the object **26**.

The mount **10** includes a circular member or element **28** outwardly projecting from the opposed leg **22** of the bracket **12**, the circular element **28** having a wedge-shaped circumferential portion **30** outwardly spaced (as by annulus **31**) from the outer surface **32** of the opposed leg **22**. The threaded bore **20** through the opposing leg **22** continues through and is concentric with the annulus **31** and circular element **28**.

The circular element **28** includes at least one groove **34** in its outer surface **36**, the groove **34** extending along a diameter of the circular element **28** and into the wedge-shaped circumferential portion **30**. The ends of the groove **34** may extend to the circumferential edge **38** of the circular element **28**, or the groove **34** may end just short of the circular element's circumferential edge **38**, and in either case the groove **34** is referred to herein as a diametric groove.

Preferably, a plurality of such diametric grooves **34** are rotationally spaced apart on the circular element's outer surface **36**. For example, a first diametric groove **34a** is shown vertically oriented as viewed in the drawing of FIG. 4, a second diametric groove **34b** is clockwise displaced by a rotational angle α from the vertically disposed groove **34a**, and a third diametric groove **34c** is clockwise displaced from the second groove **34b** by a rotational angle β . A fourth diametric groove **34d** is counterclockwise displaced from the first groove **34a**, such as by the angle α . If desired, and as preferred in the preferred embodiment, the angular displacements or angles α and β may be equal, and the third diametric groove **34c** may be horizontally oriented as viewed in the drawing of FIG. 4.

As may be apparent from the cross-sectional profile of the circular element **28** as shown in FIG. 5, the wedge-shaped circumferential portion **30** and the circular element's spacing from the outer surface **32** of the bracket **12**, may be similar to the cross-sectional profile of the commonly known Picatinny accessory mounting rail for a firearm described in MIL-STD-1913, and the preferred embodiment of the circular element of the present invention conforms to the Picatinny rail profile. Similarly, the diametric grooves **34** of the preferred embodiment of the present invention may be considered analogous to the recoil grooves provided between the longitudinally spaced-apart ribs of a Picatinny rail, and the width of the diametric grooves **34** may conform to the width of a Picatinny rail recoil groove (approximately 0.206 inch), or to the width of a recoil groove of the commonly known Universal accessory mounting rail (approximately 0.126 inch). In such manner, embodiments of the present invention may be readily adaptable for securing devices thereto that would normally interface with Picatinny or Universal accessory mounting rails. MIL-STD-1913, "Military Standard Dimensioning of Accessory Mounting Rail for Small Weapons", U.S. Department of Defense (3 Feb. 1995) is incorporated herein by reference. An example of a Picatinny rail is described in U.S. Pat. No. 6,895,708 issued to Paul Y. Kim, which patent is incorporated herein by reference.

Considering FIGS. 1 and 7 in particular, the mount **10** is shown in association with a device **40** adapted for releasable securement to the mount **10**. The example of the device **40** shown in FIGS. 1 and 7 is well known in the firearms art, and is of a type that is normally utilized for releasable securement to a Picatinny or Universal accessory mounting rail of a

firearm, the specific example shown being marketed by Sure-Fire, LLC (of Fountain Valley, Calif.) under the designation Weaver Mount Model M10.

The device **40** comprises a structural member **42** having a first securement component **44** at one end for being removably secured to the circular element **28**, such as by a Weaver style or other clamping mechanism for clampingly cooperating with the wedge-shaped circumferential portion **30** of the circular element **28**. A second component **46** at the other end of the device **40** is adapted for securing thereto an appliance **48** such as a light beam generator (including a flashlight or a laser beam apparatus) along a longitudinal axis *a*.

The first securement component **44** includes a longitudinally extending (i.e., extending parallel to the longitudinal axis *a*) protrusion **50** having a V-shaped inner surface **52** for tangentially engaging the wedge-shaped circumferential portion **30** of the circular element **28**, and further includes an opposing longitudinally extending protrusion **54** having an inclined surface **56** transversely spaced from the V-shaped inner surface **52**. A movable member **58** is transversely movable for being retained by the protrusion **54** and includes an inclined surface **60** such that, when the member **58** is transversely moved for engagement with the protrusion **54**, the two inclined surfaces **56**, **60** are configured as a V-shaped inner surface for tangentially engaging the wedge-shaped circumferential portion **30** of the circular element **28** at a location diametrically opposed to the location at which the V-shaped inner surface **52** of the protrusion **50** tangentially engages the circular element **28**. For this purpose, one end of a transverse bar **62** is retained by the protrusion **50**, while the other end of the bar **62** extends through an opening **64** in protrusion **54** and through an aperture **66** in movable member **58**, such other end threadedly engaging a knurled knob **68** for releasably urging the movable member **58** against the protrusion **54** when the knurled knob **68** is threadably tightened against the movable member **58**, thereby releasably clamping the two opposing V-shaped inner surfaces against the wedge-shaped circumferential portion **30** of the circular element **28** at two diametrically opposed locations.

Each of the diametric grooves **34** is configured for engageably receiving at least a portion of the bar **62**, so that the width of each of the diametric grooves **34** is slightly greater than the width of the transverse bar **62**. During installation of the device **40** to the mount **10**, the user selects the orientation of the device **40** (and hence the orientation of the light beam generator **48** secured to the device **40**) by selecting one of the diametric grooves **34** of differing orientation, placing the device **40** to the circular element **28** with the protrusions **50** and **54** engaging the circular element's wedge-shaped circumferential portion **30** and with the bar **62** disposed in the selected diametric groove **34**, and threadably rotating the knurled knob **68** to urge the moveable member **58** tightly against the outer surface of the protrusion **54** and the inner surface of the circular element's wedge-shaped circumferential portion **30**. Loosening rotation of the knurled knob **68** permits the device **40** shown in FIGS. 1 and 7 to be removed from the mount **10**.

The second securement component **46** comprises a generally arcuate longitudinally extending shell hinged to the structural member **42** along one longitudinal side **72** and adjustably retained to the structural member **42** along its other side **74**. The arcuate shell **70** faces a longitudinally extending arcuate surface **76** of the structural member **42** for securely holding a generally cylindrical portion of an appliance such as the light beam generator **48** along its longitudinal axis *a*.

Another example of a prior art device for holding a light beam generator, which device may be used for being clamped

5

to the mount **10** of the present invention, is shown in FIG. 2 of U.S. Pat. No. 6,994,449 issued to Paul Y. Kim, which patent is incorporated herein by reference.

FIGS. 8 and 9 represent two orientations of the device **40** (and hence of the light beam generator **48** secured thereto) with respect to the mount **10** which in turn may be secured to an object **26** as represented in FIG. 7. The object **26** may be a plate or any other support structure, an example of which may be a rim of a helmet. In FIG. 8, the device **40** is secured to the mount **10** with the bar **62** retained in the vertically disposed diametric groove **34a** (see FIG. 4), resulting in the light beam generator **48** being horizontally oriented. In FIG. 9, the device **40** is secured to the mount **10** with the bar **62** disposed in the diametric groove **34b**, resulting in the light beam generator **48** being displaced by the angle α from its orientation represented in FIG. 8. Similarly the device **40** may be secured to the mount **10** with the bar **62** disposed in one of the other grooves **34c** or **34d**, resulting in the light beam generator **48r** being retained in a vertical orientation or in a reverse α -angle displaced orientation, respectively.

The device **40** may be considered as an interface between the mount **10** and an appliance such as the light beam generator **48**. It is evident that the combination of such interface and the secured appliance or light beam generator may be considered as an integral device **40** for being secured to the mount **10** of the present invention.

Similarly, the light beam generator or other appliance may itself include a Weaver style or other clamping mechanism, along with a bar mechanism for engaging the diametric grooves **34** of the circular element **28**, for directly and removably securing the appliance or light beam generator to the circular element of the mount **10** of the present invention in selected orientations. An example of such an integral appliance, specifically a light beam generator, is described in U.S. Pat. No. 7,117,624, issued to Paul Y. Kim and incorporated herein by reference.

Thus, there has been described a preferred embodiment of a mount for removably securing a device to an object, with the orientation of the device with respect to the object being selectable by a user. Other embodiments of the present invention, and variations of the embodiment presented herein, may be developed without departing from the essential characteristics thereof. Accordingly, the invention should be limited only by the scope of the claims listed below.

I claim:

1. Apparatus for mounting a device to an object, comprising:

a mount securable removably secured to the object, said mount including a circular element having a wedge-shaped circumferential portion and at least one diametric groove; and

a device including first and second opposed surfaces for securingly engaging said circular element at said wedge-shaped circumferential portion, said device including a

6

bar extending between said first and second opposed surfaces at least a portion of said bar received by a one of said at least one diametric groove.

2. The apparatus according to claim **1**, wherein: said first and second opposed surfaces extend substantially parallel to a longitudinal axis of said device.

3. The apparatus according to claim **1**, wherein: said device is adapted for clamping said opposed surfaces to said circular element at said wedge-shaped circumferential portion.

4. The apparatus according to claim **1**, wherein: said at least one diametric groove comprises a plurality of rotationally spaced diametric grooves.

5. The apparatus according to claim **4**, wherein: each of said diametric grooves is configured for engageably receiving at least a portion of said bar.

6. The apparatus according to claim **4**, wherein: said first and second opposed surfaces extend substantially parallel to a longitudinal axis of said device.

7. The apparatus according to claim **4**, wherein: said device is adapted for clamping said opposed surfaces to said circular element at said wedge-shaped circumferential portion when said bar engages a selected one of said diametric grooves.

8. The apparatus according to claim **4**, wherein: said diametric grooves are three in number.

9. The apparatus according to claim **4**, wherein: said diametric grooves are rotationally equally spaced.

10. The apparatus according to claim **1**, wherein: said device includes an appliance.

11. The apparatus according to claim **1**, wherein: said device is adapted for securing an appliance thereto.

12. The apparatus according to claim **1**, wherein: said device includes a light beam generator.

13. The apparatus according to claim **1**, wherein: said device is adapted for securing a light beam generator thereto.

14. The apparatus according to claim **4**, wherein: said device includes an appliance.

15. The apparatus according to claim **4**, wherein: said device is adapted for securing an appliance thereto.

16. The apparatus according to claim **4**, wherein: said device includes a light beam generator.

17. The apparatus according to claim **4**, wherein: said device is adapted for securing a light beam generator thereto.

18. The apparatus according to claim **4**, including an appliance having a longitudinal axis secured to said device; and wherein

said first and second opposed surfaces extend substantially parallel to said longitudinal axis.

19. The apparatus according to claim **18**, wherein: said appliance comprises a light beam generator.

* * * * *