



US006655069B2

(12) **United States Patent**  
**Kim**

(10) **Patent No.:** **US 6,655,069 B2**  
(45) **Date of Patent:** **Dec. 2, 2003**

- (54) **ACCESSORY MOUNTS FOR SHOTGUNS AND OTHER FIREARMS**
- (75) Inventor: **Paul Y. Kim**, Westminster, CA (US)
- (73) Assignee: **Surefire, LLC**, Fountain Valley, CA (US)
- (\* ) Notice: Subject to any disclaimer, the term of this patent is extended or adjusted under 35 U.S.C. 154(b) by 0 days.
- (21) Appl. No.: **10/021,814**
- (22) Filed: **Dec. 12, 2001**
- (65) **Prior Publication Data**  
US 2003/0106251 A1 Jun. 12, 2003
- (51) **Int. Cl.**<sup>7</sup> ..... **F41G 1/34**
- (52) **U.S. Cl.** ..... **42/114; 42/115; 42/148**
- (58) **Field of Search** ..... 42/112, 114, 115, 42/116, 117, 143, 148

4,663,875 A	5/1987	Tatro	
4,733,489 A	3/1988	Kurak	
4,742,636 A	5/1988	Swan	
4,845,871 A	7/1989	Swan	
4,856,218 A	8/1989	Reynolds, Jr.	
4,941,277 A *	7/1990	Lawlor	42/100
5,010,676 A	4/1991	Kennedy	
5,027,542 A *	7/1991	Simonetti	42/72
5,033,219 A *	7/1991	Johnson et al.	362/289
5,068,992 A *	12/1991	Velezis et al.	42/73
5,092,071 A	3/1992	Moore	
5,111,587 A	5/1992	Plank	
5,142,806 A	9/1992	Swan	
5,198,600 A	3/1993	E'Nama	
5,201,135 A	4/1993	Cowles	
5,343,650 A	9/1994	Swan	
5,533,292 A	7/1996	Swan	
5,590,484 A	1/1997	Mooney et al.	
5,634,288 A	6/1997	Martel	
5,704,155 A	1/1998	Primeau, IV	
5,727,346 A	3/1998	Lazzarini et al.	
5,826,363 A *	10/1998	Olson	42/75.01
6,012,374 A	1/2000	Brandl et al.	
6,374,528 B1 *	4/2002	Davis et al.	42/71.01

- (56) **References Cited**  
**U.S. PATENT DOCUMENTS**
- 1,501,211 A \* 7/1924 Forin
- 2,128,936 A 9/1938 Green
- 2,287,066 A 6/1942 Rogers
- 2,402,086 A 6/1946 Rix
- 2,826,848 A \* 3/1958 Davies
- 2,965,994 A 12/1960 Sullivan
- 3,075,314 A 1/1963 Bakker
- 3,090,150 A 5/1963 Stoner
- 3,447,033 A \* 5/1969 Redmond et al.
- 3,513,581 A 5/1970 Slater
- 3,857,323 A 12/1974 Ruger et al.
- 4,087,930 A 5/1978 Grehl
- 4,310,982 A 1/1982 Kast et al.
- 4,536,982 A 8/1985 Bredbury et al.
- 4,627,183 A 12/1986 Stuckman

**OTHER PUBLICATIONS**

United States Department of Defense, Military Standard: Dimensioning of Accessory Mounting Rail for Small Arms Weapons, Feb. 3, 1995.

\* cited by examiner

*Primary Examiner*—Stephen M. Johnson  
(74) *Attorney, Agent, or Firm*—David Weiss

(57) **ABSTRACT**

Accessory mounts for firearms, including a combined hand-grip and accessory mount for a shotgun, as well as detachably securable rails and modified Picatinny rails for mounting accessories to shotguns and other firearms.

**18 Claims, 3 Drawing Sheets**

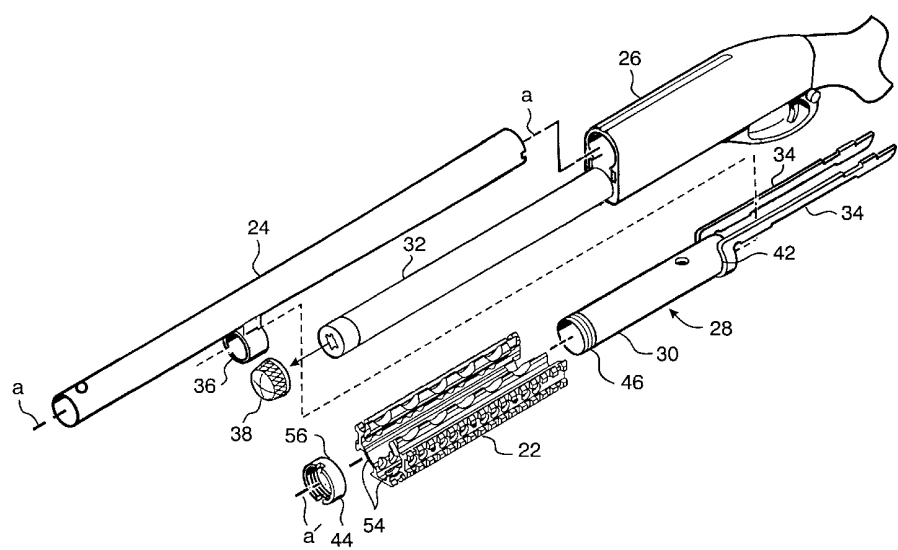

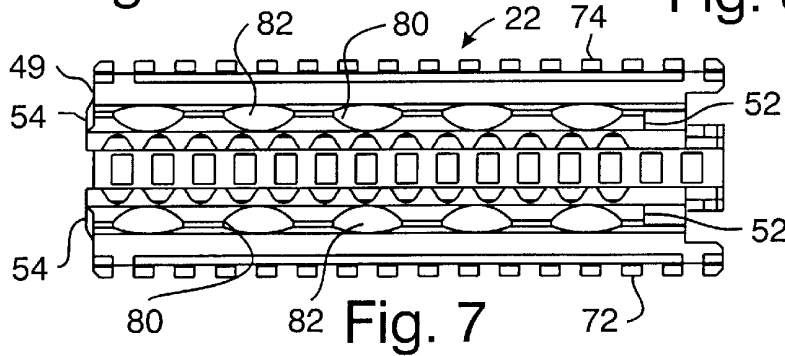
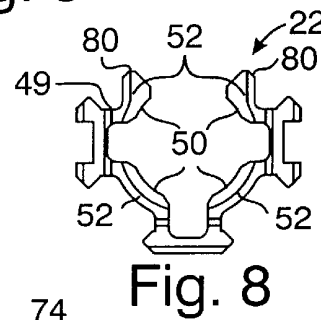
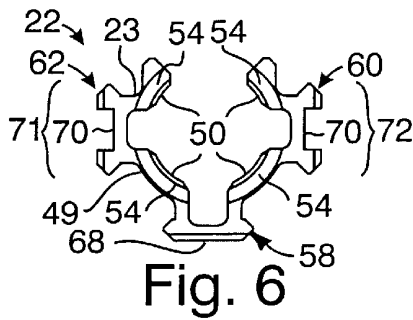
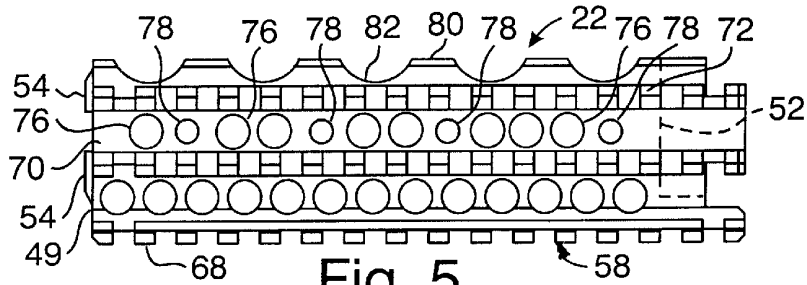
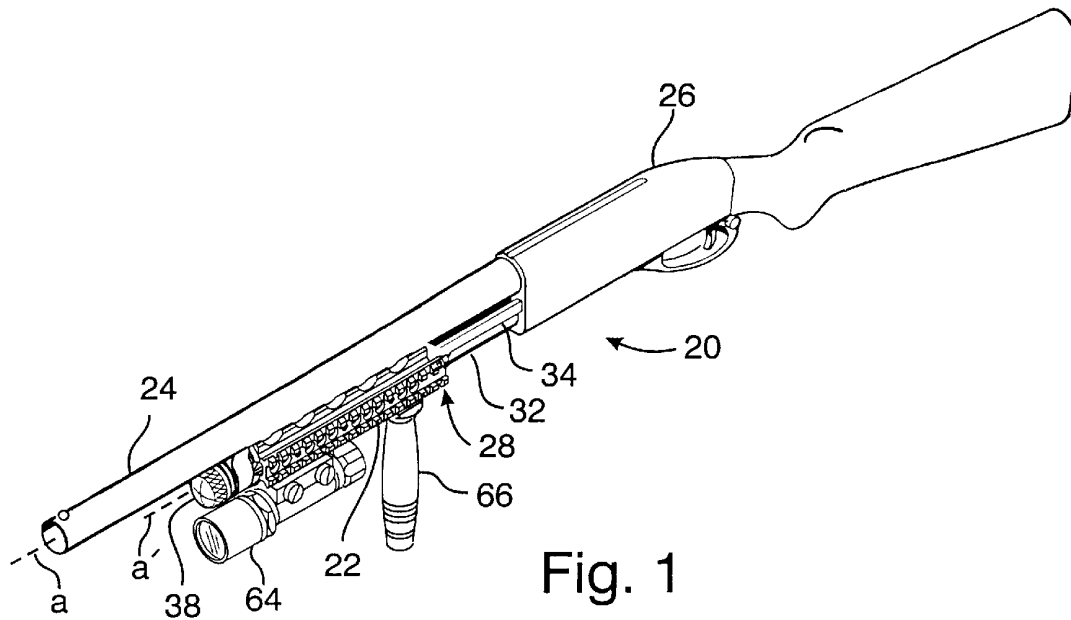

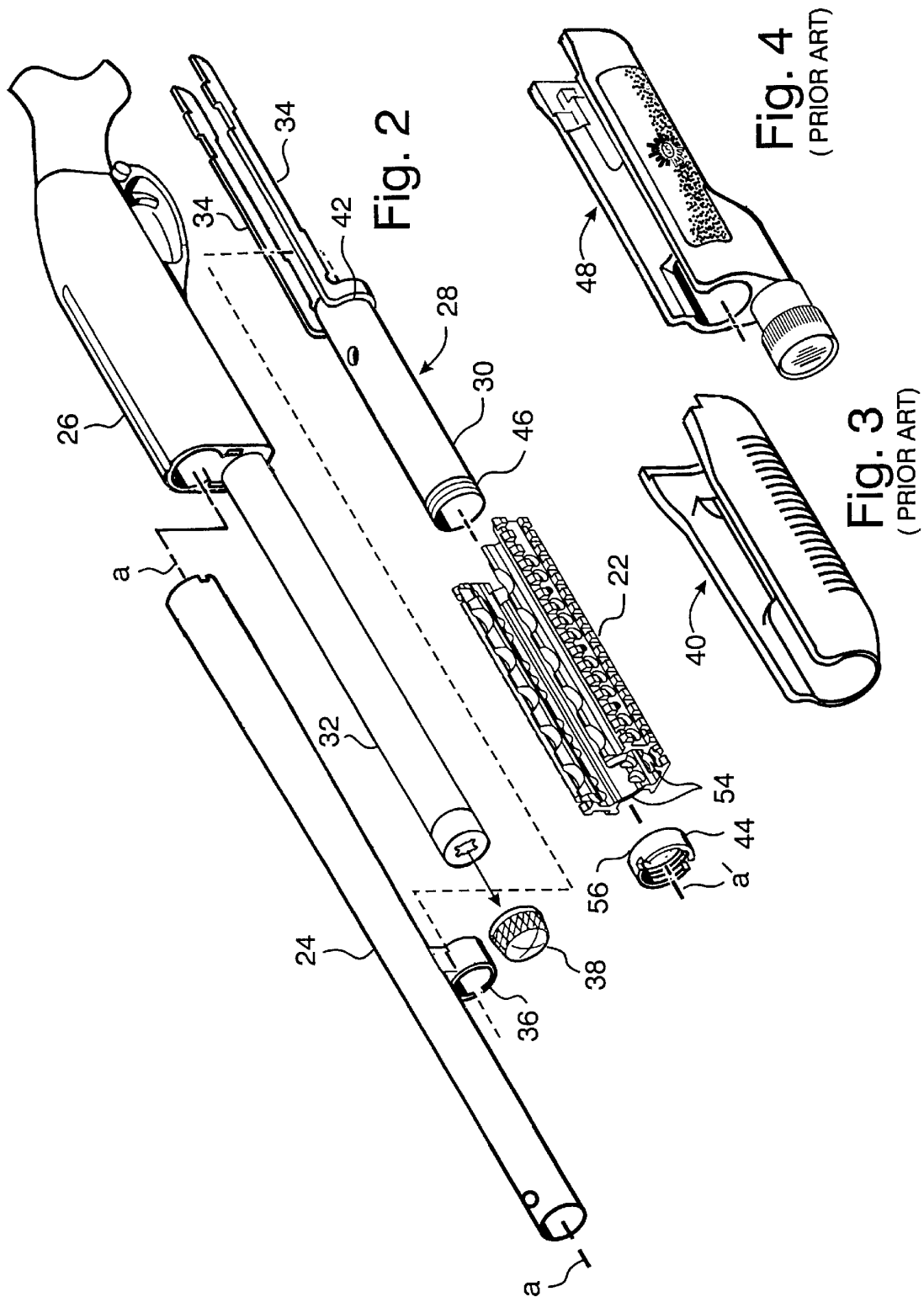

Fig. 2

Fig. 4  
(PRIOR ART)

Fig. 3  
(PRIOR ART)

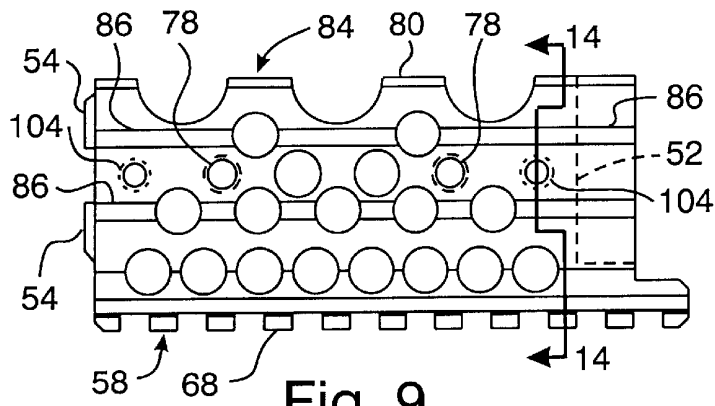

Fig. 9

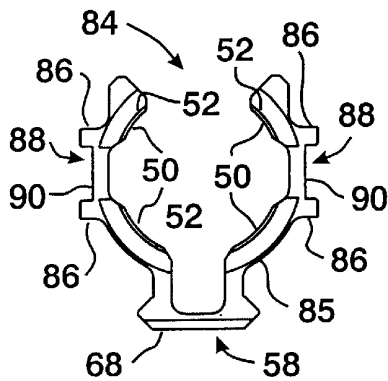

Fig. 10

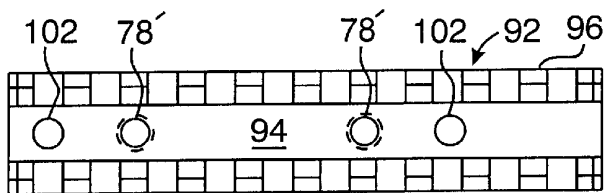

Fig. 11

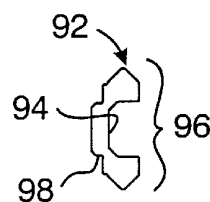

Fig. 13

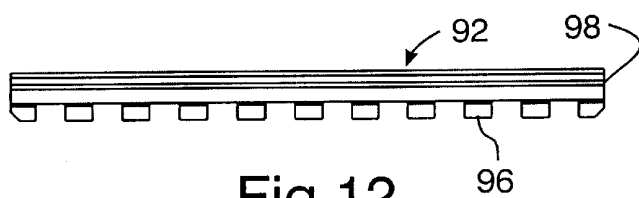

Fig. 12

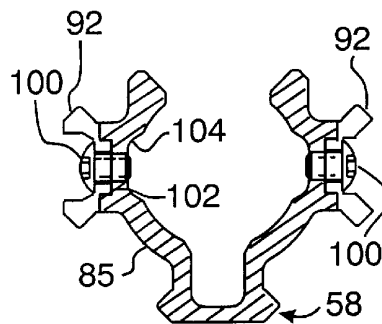

Fig. 14

## ACCESSORY MOUNTS FOR SHOTGUNS AND OTHER FIREARMS

### BACKGROUND OF THE INVENTION

This invention relates to accessory mounts for firearms, and more particularly to a combined handgrip and accessory mount for shotguns as well as to accessory mounts for other types of firearms.

Various types of devices are useful as accessories for being mounted to firearms, examples of such accessories being target illuminators and vertical pistol grips. Such accessories are conventionally mounted to an interface apparatus descriptively referred to as an accessory mount, which has been secured to the firearm. Such accessory mounts may include rail interface systems well known in the art pertaining to firearms, and in particular with respect to submachine guns, carbines, rifles and other firearms used for military and police operations.

### SUMMARY OF THE INVENTION

The present invention provides further applications of and improvements to rail interface mounts for firearm accessories. According to one aspect of the present invention, there is provided a combined handgrip and accessory mount for a shotgun having a longitudinally moveable fore-end assembly, the handgrip/mount comprising: a shell adapted to be secured to the fore-end assembly for manually moving the fore-end assembly; and at least one rail structure on the shell for mounting a firearm accessory to the at least one rail structure. According to a preferred embodiment thereof, the shell includes interior arcuate sections for fitting the shell about a moveable fore-end tube of the shotgun's fore-end assembly, the shell adapted to be secured to the fore-end tube. The rail structures may include the well known Picatinny rail, although another aspect of the present invention is a modified version of the Picatinny rail in which the rail includes a channel longitudinally therealong, which channel includes a longitudinally extending wall having at least one aperture therethrough, and the shell is adapted for securing a firearm accessory to the shell through such aperture.

Another preferred embodiment of the combined handgrip and accessory mount for a shotgun, according to the present invention, comprises: a shell adapted to be secured to the shotgun's longitudinally moveable fore-end assembly, for manually moving the fore-end assembly; and at least one rail member adapted to be detachably secured to the shell for mounting a firearm accessory to the at least one rail member when the at least one rail member is secured to the shell. In a preferred embodiment thereof, the shell includes at least one longitudinal groove therealong, and the rail member includes a lateral projection longitudinally extending along the rail member for being received by the longitudinal groove when the rail member is secured to the shell. The longitudinal groove may comprise a longitudinally extending channel between two laterally outward projections longitudinally extending along the shell, and the lateral projection along the rail member projects laterally inwardly for being received by the channel of the shell. The handgrip/mount preferably includes two such longitudinal grooves or channels, each on opposite sides of the shell, for detachably securing two side rails to the shell for mounting a firearm accessory to one or each of the side rail members; in addition, the shell preferably includes a rail structure longitudinally extending along the shell's bottom for mounting a firearm accessory to the bottom rail structure.

The modified Picatinny rails of the present invention, as well as the provision of rail members which are detachably securable to the shell of the accessory mount, may be implemented in accessory mounts for shotguns as well as in accessory mounts for other firearms.

### BRIEF DESCRIPTION OF THE DRAWINGS

The novel features believed to be characteristic of the invention, together with further advantages thereof, will be better understood from the following description considered in connection with the accompanying drawings in which preferred embodiments of the present invention are illustrated by way of example. It is to be expressly understood, however, that the drawings are for the purpose of illustration and description only and are not intended as a definition of the limits of the invention.

FIG. 1 is a perspective view of an example of a shotgun to which there is secured a preferred embodiment of an accessory mount according to the present invention, specifically a preferred embodiment of a combined handgrip and accessory mount;

FIG. 2 is an exploded perspective view of parts of the shotgun and handgrip/mount embodiment of FIG. 1, in increased scale;

FIG. 3 is an example of a conventional handgrip for a shotgun that is replaced by the handgrip/mount embodiment of the present invention;

FIG. 4 is a prior art combined handgrip and target illuminator device for a shotgun;

FIG. 5 is a side elevation view of the preferred embodiment of the handgrip/mount shown in FIGS. 1 and 2, in further increased scale;

FIG. 6 is an elevation view of the front end of the handgrip/mount of FIG. 5;

FIG. 7 is a top plan view of the handgrip/mount of FIG. 5;

FIG. 8 is an elevation view of the rear end of the handgrip/mount of FIG. 5;

FIG. 9 is a side elevation view of a second preferred embodiment of an accessory mount for a firearm according to the present invention, specifically a second preferred embodiment of a combined handgrip and accessory mount for a shotgun, shown in further increased scale;

FIG. 10 is an elevation view of the front end of the accessory mount of FIG. 9;

FIG. 11 is a side elevation view of a rail structure that may be detachably secured to the accessory mount of FIG. 9;

FIG. 12 is a top plan view of the detachably securable rail of FIG. 11;

FIG. 13 is an elevation view of an end of the rail of FIG. 11; and

FIG. 14 is a cross-sectional view of the accessory mount of FIG. 9 taken along the line 14—14 in the direction of the appended arrows, shown with the rail of FIGS. 11—13 attached thereto.

### DETAILED DESCRIPTION OF THE PREFERRED EMBODIMENT

Turning first to FIGS. 1 and 2, there is illustrated an example of a shotgun 20, such as a Remington Model 870 shotgun manufactured by Remington Arms Company, Inc. (of Madison, N.C.), equipped with a preferred embodiment of a combined handgrip and accessory mount 22 (or "handgrip/mount") in accordance with the present invention.

The shotgun **20** includes a barrel **24** extending along a longitudinal axis *a* from the shotgun's receiver **26**. As is well known in the firearms art, the shotgun **20** further includes a fore-end assembly **28** including a fore-end tube **30** that is longitudinally moveable (i.e. moveable along a longitudinal axis *a*' generally parallel to the axis *a*) along a magazine tube **32**. Dual action bars **34**, projecting rearwardly from the fore-end tube **30**, extend into the receiver **26** for actuating mechanisms for ejecting spent cartridges, chambering live cartridges and cocking the shotgun's hammer device.

The magazine tube **32** extends generally longitudinally from the receiver **26** and below the barrel **24**, and a forward portion of the magazine tube **32** engages a barrel lug **36** and held thereto by a magazine cap **38**.

It is also well known that such fore-end assemblies **28** have a handgrip secured to the fore-end tube **30**, such as the conventional handgrip **40** shown in FIG. 3, for manually moving the fore-end tube **30** longitudinally along the magazine tube **34** upon which the fore-end tube **30** is slideably carried. Shotguns are ordinarily equipped with a conventional handgrip **40** when purchased, such handgrip **40** being secured to the fore-end tube **30** and against forward shoulders **42** of the action bars **34** by means of an internally threaded retainer nut **44** threadedly secured to the externally threaded forward end section **46** of the fore-end tube **30**. As taught in U.S. Pat. No. 4,856,218 to Edward C. Reynolds, Jr., the conventional handgrip **40** may be replaced by a combined handgrip and target illuminator device **48**, mounted on the fore-end tube **30** in the same manner as was the original equipment handgrip **40** and secured with the same retainer nut **44**. U.S. Pat. No. 4,856,218 is incorporated herein by reference. Similarly, the handgrip/mount **22** of the present invention may replace and be substituted for the original equipment conventional handgrip **40**, which handgrip/mount **22** may be secured to the movable fore-end tube **30** by the same retainer nut **44** as shown in FIGS. 1 and 2.

Turning to FIGS. 5-8, the preferred embodiment of the combined handgrip and accessory mount **22** includes a generally cylindrical shell **49** of greater than semi-circular cross-section, the shell **49** including interior arcuate surface sections **50** of a diameter slightly greater than the outside diameter of the shotgun's fore-end tube **30**, for permitting the handgrip/mount **22** to be slip-fit about and carried by the fore-end tube **30**. Near the rear end of the handgrip/mount **22**, the sections **50** are recessed to provide rearwardly facing shoulders **52** for abutting the forwardly facing rear shoulders or stops **42** of the fore-end tube **30**. At the front end of the handgrip/mount **22**, the sections **50** terminate with a forwardly facing edge **54** (which may be forwardly inclined) for abutting the rearwardly facing edge **56** (which may be beveled) of the retainer nut **44** (see FIG. 2), when the handgrip/mount **22** is carried by the fore-end tube **30** with the handgrip/mount's rear shoulders **52** abutting the fore-end tube stops **42** while the retainer nut **44** is threaded upon the threaded forward end section **46** of the fore-end tube **30**. The length of the handgrip/mount **22** between its rear shoulders **52** and its front edges **54** is such that the tightening of the retainer nut **44** causes the rear shoulders **52** to bear against the stops **42**, thereby securing the handgrip/mount **22** to the fore-end tube **30**.

The preferred embodiment of the handgrip/mount **22** includes at least one longitudinal rail structure along the shell **49** (preferably along the entire length of the shell **49** as shown in FIGS. 5-14), such as a bottom rail structure **58** along the exterior underside thereof, and which also may include side rail structures **60, 62**, to which may be mounted

firearm accessories such as a target illuminator **64** and/or a vertical or pistol grip **66** as shown in FIG. 1, as well as other devices. Rails for accessory mounts are well known in the firearms art, for example as contained on rail interface system devices such as manufactured by Knight's Manufacturing Company (of Vero Beach, Fla.), including those disclosed in U.S. Pat. No. 5,826,363 to Douglas D. Olson, as well as those disclosed in U.S. Pat. No. 5,590,484 to Aurelius A. Mooney et al., both of which patents are incorporated herein by reference. One such prior art rail comprises a series of longitudinally spaced-apart ribs **68**, such as specified in MIL-STD-1913 and commonly known as a Picatinny rail, which is shown in FIGS. 6 and 8 as comprising the bottom rail **58**. Although such Picatinny rails may be used for the side rail structures **60, 62** as well, the preferred handgrip/mount **22** of the present invention includes a modified version of the Picatinny rail for the side rails **60, 62**, which modified Picatinny rail may be used for the bottom rail **58** as well. The modified Picatinny rail of the present invention includes a slot or channel **70** longitudinally extending along each of the rails **60** and **62** through the ribs **72** and **74**, such ribs being oriented perpendicular to the longitudinal axis *a*'. Either type of rail structure may be utilized for securing accessories having a Weaver style or other cooperating clamping device, although the provision of the channel **70** provides greater adaptability of accessory arrangement on a rail as well as additional types of securement opportunities. Further, the wall of each channel **70** may include apertures **76** therethrough, for weight and/or heat reducing purposes, as well as longitudinally spaced apart apertures **78** preferably with internal threads for securement of accessories by other securement devices (e.g. screws) instead of or in addition to securement by utilization of the rails **58, 60** and/or **62** alone. The top edges **80** of the handgrip/mount **22** may be provided with longitudinally spaced-apart concave notches **82** serving as finger grips as well as for providing weight and/or heat reduction.

The handgrip/mount **22** may be manufactured using fabrication methods well known in the art, of well known materials typically used in the art of making firearm accessory mounts including metals such as lightweight aluminum alloys and other rigid and durable materials such as polymeric materials.

When installing the handgrip/mount **22** on the shotgun **20** (see FIGS. 2 and 3), the user removes the magazine cap **38** from the magazine tube **32**, forwardly moves or removes the barrel **24** so as to release the lug **36** from magazine tube **32**, removes the retainer nut **44** from the threaded forward end section **46** of the fore-end tube **30**, and removes the original equipment handgrip **40** from the fore-end tube **30**. The user then slides the handgrip/mount **22** onto the fore-end tube **30** until its rearwardly facing shoulders **52** abut the stops **42**; the retainer nut **44** is thereupon threaded onto the front end section **46** of the fore-end tube **30**. The barrel **36** is reinstalled to the receiver **26** with the barrel lug **36** engaging the magazine tube **32**, and the magazine cap **38** is replaced. The handgrip/mount **22** may be removed from the shotgun **20** by reversing the installation procedure and reinstalling the original equipment handgrip **40** if desired.

In use, the user grips the handgrip/mount **22** in the same manner that he/she would ordinarily grip the original equipment handgrip **40**, for manipulating the fore-end tube **30** to longitudinally slide along the magazine tube **32** for causing the action bars **34** to perform their actuating functions.

The handgrip/mount **22** of the present invention has advantages over handgrips of the prior art in that a variety of commercially available firearm accessory devices such as

target illuminators (for example, target illuminators marketed by Surefire, LLC, of Fountain Valley, Calif.) one example **64** of which is shown in FIG. 1, may be detachably mounted thereto in positions which are convenient to the user and which would not interfere with the function of the handgrip/mount **22** as a handgrip. The mounting thereto of a commercially available vertical or pistol grip (for example, vertical pistol grips marketed by Knight's Manufacturing Company, of Vero Beach, Fla., such as the example **66** shown in FIG. 1) provides additional advantage in facilitating the handgrip/mount **22** in its use as a handgrip for a shotgun, particularly since the pistol grip **66** may be adjustably positioned longitudinally along the handgrip/mount **22** as well as the ability for the pistol grip to be secured to the side rail in a horizontal position.

The second preferred embodiment of a handgrip/mount **84** according to the present invention, shown in FIGS. 9-14—although the example shown is of a different length than the example of the first preferred embodiment **22** of FIGS. 5-8 for accommodating a fore-end tube **30** of shorter length—is similar in structure and operation to the first preferred embodiment **22** depicted in FIGS. 6-8 and described above, except as described below. Accordingly, like reference numerals are employed in FIGS. 9-14 for like components in FIGS. 6-8.

In the second preferred embodiment of the handgrip/mount **84**, the side rails are removable from and attachable to the shell **85** of the handgrip/mount **84**. Each of the two or opposite sides of the shell **85** includes a longitudinal groove preferably comprising two laterally outward projections **86** longitudinally extending along said shell **85**, each pair of projections **86** separated by a longitudinally extending channel **88** including a wall **90** which, in the example of FIG. 10, is shown vertically disposed.

A longitudinal rail member **92**, shown in FIGS. 11-13, comprises a series of longitudinally spaced-apart ribs such as in a Picatinny rail, and preferably as in the modified Picatinny rail described above and which includes a slot or channel **94** (similar to the channel **70** of FIGS. 5 and 6) longitudinally extending through ribs **96** (similar to the ribs **72** or **74** of FIGS. 5 and 6). A laterally inward projection **98** longitudinally extending along said rail member **92** opposite the channel **94**, is configured to be received by and mate with the groove or channel **88** between the pair of lateral projections **86** of the shell **85**, and to be secured thereto such as by screws **100** (see FIG. 14) through apertures **102** through the projection **98** and threadedly engaging threaded apertures **104** in the wall **90** of the channel **88**.

The handgrip/mount **84** may be used without the rail members **92** secured thereto, as shown in FIGS. 9 and 10, in which case firearm accessories may be mounted to the lower rail structure **58**, as well as to the channel walls **90** by utilization of the threaded apertures **78** in the shell **85**. Alternatively, one or both of the side rail members **92** may be secured to the shell **85**, as shown in FIG. 14, in which case firearm accessories may be mounted to the bottom rail structure **58** and/or the side rail members **92**, as well as to the shell **85** by utilization of the threaded apertures **78** in the shell **85** communicating with apertures **78'** in the side rail member **92** (which aperture **78'** may also be threaded). The side rail members **92** may be detached from the handgrip/mount **84** by removing the screws **100**, if desired.

It may be appreciated that the detachably securable rail members **92** may be used as well in a rail mount device for firearms other than in combination with a handgrip for a shotgun, which case such other rail mount device includes

an accommodation securing the rail member **92** thereto, for example an accommodation for securably receiving the rail member **92** such as a longitudinal channel **88** in the mount for securably receiving a longitudinal projection **98** of the rail member **92**.

Thus, there have been described preferred embodiments of accessory mounts for firearms, including a combined handgrip and accessory mount for a shotgun, as well as detachably securable rails and modified Picatinny rails for mounting accessories to shotguns and other firearms. Other embodiments of the present invention, and variations of the embodiment described herein, may be developed without departing from the essential characteristics thereof. Accordingly, the invention should be limited only by the scope of the claims listed below.

I claim:

1. Shotgun and accessory mount apparatus, comprising in combination:

a shotgun having a longitudinally moveable fore-end assembly;

a shell secured to said fore-end assembly for manually moving said fore-end assembly; and

at least one longitudinal rail structure on said shell for mounting a firearm accessory to said shell in a longitudinally adjustable position therealong.

2. The apparatus according to claim 1, wherein:

said fore-end assembly includes a moveable fore-end tube; and

said shell is fitted about and secured to said fore-end tube.

3. The apparatus according to claim 1, wherein:

said at least one rail structure includes a rail longitudinally extending along a bottom of said shell.

4. The apparatus according to claim 3, wherein:

said rail along said bottom of said shell comprises a Picatinny rail.

5. The apparatus according to claim 3, wherein:

said at least one rail structure includes a rail longitudinally extending along a side of said shell.

6. The apparatus according to claim 5, wherein:

said rail longitudinally extending along a side of said shell comprises a Picatinny rail.

7. The apparatus according to claim 1, wherein:

said at least one rail structure includes a longitudinal rail for mounting a firearm accessory to said rail and further includes a channel longitudinally along said rail.

8. The apparatus according to claim 7, wherein:

said channel includes a longitudinally extending wall having at least one aperture therethrough; and

said shell is adapted for securing a firearm accessory thereto through said at least one aperture.

9. The apparatus according to claim 1, wherein:

said shell includes at least one longitudinally extending wall adapted for securing a firearm accessory thereto.

10. The apparatus according to claim 1, further including: a pistol grip mounted to a one of said at least one rail structure.

11. The apparatus according to claim 1, including:

a target illuminator detachably mounted to a one of said at least one longitudinal rail structure.

12. Shotgun and accessory mount apparatus, comprising in combination:

a shotgun having a longitudinally moveable fore-end assembly;

a shell secured to said fore-end assembly for manually moving said fore-end assembly; and

7

at least one rail structure on said shell for mounting a firearm accessory to said shell, said at least one rail structure longitudinally extending along substantially the entire length of said shell.

13. The apparatus according to claim 12, wherein: 5

said at least one rail structure includes a rail longitudinally extending along a bottom of said shell.

14. The apparatus according to claim 13, wherein:

said at least one rail structure includes a rail longitudinally extending along a side of said shell. 10

15. The apparatus according to claim 13, including:

a pistol grip detachably mounted to said rail longitudinally extending along the bottom of said shell.

16. The apparatus according to claim 12, including: 15

a target illuminator detachably mounted to a one of said at least one rail structure.

8

17. Shotgun and accessory mount apparatus, comprising in combination:

a shotgun having a longitudinally moveable fore-end assembly;

a shell secured to said fore-end assembly for manually moving said fore-end assembly;

at least one longitudinal rail structure on said shell; and

a target illuminator detachably mounted to said at least one longitudinal rail structure.

18. The apparatus according to claim 17, including:

a pistol grip detachably mounted to a one of said at least one longitudinal rail structure.

\* \* \* \* \*